

## Retail Price List 2008

**ORIGINAL SERIES.** Our Original Series feature our unique rounded tips for safety, convenient holes for hanging, and thin (1.5mm) blades for effortless slicing.

	PK-40 Paring Knife 4" Peeling small fruits & vegetables	\$25.00
	FK-70 Fillet Knife 6¾" Filleting fish, deboning poultry	\$45.00
	UK-60 Utility Knife 6¾" All-purpose cutting & slicing	\$47.50
	UK-80 Utility Knife 7½" All-purpose cutting & slicing	\$57.50
	CK-90 Carving Knife 9" Carving roasts, slicing melons	\$67.50
	CL-6 Cleaver-Med. Duty 6½" Chopping small chicken, duck, & fish bones. 3.0 mm blade	\$80.00





**SUPERIOR SERIES.** This updated line of our Original Series has larger handles & slightly thicker (2 mm) blades for more weight & strength. The improved Tungsten alloy provides a longer lasting edge and makes resharpening easier.

	SP-50 Paring Knife 5" Paring small fruits & vegetables	\$37.50
	SA-70 Utility Knife 7" All-purpose cutting, dicing & slicing	\$77.50
	SA-80 Utility Knife 8" All-purpose cutting, dicing & slicing	\$85.00
	SK-40 Santoku Paring Knife 4" Paring small fruits & vegetables	\$37.50
	SK-65 Santoku 6½" Japanese style all-purpose	\$70.00
	SF-85 Fillet Knife 8¼" Filleting fish, slicing roasts & ham	\$85.00
	SD-65 Cleaver 6½" Chopping chicken & fish bones	\$95.00
	SB-105 Bread/Roast 10½" Slicing breads, roasts & cakes	\$85.00

**CHEF SERIES.** This series consists of value priced knives for a wide range of applications. Same Molybdenum alloy as the Original Series.

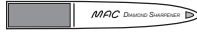
	PK-25 Bird's Beak Parer 2½" Peeling & fine work	\$30.00
	HB-55 Paring 5½" Peeling, paring, trimming	\$37.50
	HB-70 Utility Knife 7¼" All-purpose cutting & slicing	\$55.00
	HB-85 Utility Knife 8½" All-purpose cutting & slicing	\$65.00
	BK-80 French Chef's 8" All around use--dicing, slicing mincing, chopping.	\$90.00
	BK-100 French Chef's 10" 10" version of the above	\$105.00
	BK-120 French Chef's 12" 12" version of the above	\$120.00
	MK-40 Cheese Knife 3¾" Cutting cheese, spreading, paring & steak knife	\$30.00
	BNS-60 Boning 6", straight Deboning chicken, fish, pork	\$42.50
	PB-60 Boning 6", plas. handle Deboning chicken, fish, pork	\$35.00
	BS-90 Bread/Roast Slicer 8¾" Slicing breads, cakes, hams, & roasts.	\$60.00
	BSC-85 Sushi Chef 8½" Black, non-stick coating glides through sushi rolls and resists "sticking" to rice.	\$72.50
	TH-80 Cooks 8", Dimpled Excellent all purpose knife. Slides through cuts. Excellent for starchy potatoes.	\$95.00
	TH-100 Cooks 10", Dimpled Longer version of the TH-80	\$115.00

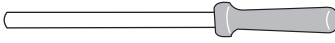
**SHARPENERS.** We recommend only these sharpeners for MAC knives.

	SS-1 Ceramic whetstone Rebeveling & sharpening	\$12.50
	DS-1 Diamond sharpener Rebeveling & sharpening	\$25.00
	TCS-2 Sharpener Tungsten Carbide/Ceramic For serrated knives & shears	\$17.50
	SR-85 Sharpening Rod 8½" Ceramic, Medium grit (800) Touches up and maintains edge	\$20.00
	SR-2 Rollsharp The easiest, simplest tool to sharpen & hone your MAC knives.	\$16.50







**PROFESSIONAL SERIES.** For the serious Chef who prefers classic shapes and weighted bolsters for added heft and balance. Our Molybdenum alloy.

	PKF-30 Pro Paring 3 1/4" Peeling, paring, & fine work	\$55.00
	PKF-50 Pro Paring 5" Peeling, paring, & trimming	\$60.00
	PKF-60 Pro Utility 6" Paring, slicing, and small utility	\$65.00
	SO-70 Pro Sole Fillet 7" Flexible blade for filleting fish	\$130.00
	MSK-65 Mighty Santoku 6 1/2" All-purpose, extra control. Glides through potatoes. Tungsten alloy	\$120.00
	MTH-80 Mighty Chef 8 1/2" Standard, Chef's w/ dimples All-purpose, glides through cuts. Tungsten alloy	\$145.00
	MBK-85 Mighty Chef 8 1/2" Standard, classic French Chef's All purpose workhorse.	\$155.00
	MBK-95 Mighty Chef 9 1/2" Standard, classic French Chef's	\$175.00
	MBK-110 Mighty Chef 10 3/4" French Chef's for slicing, dicing, cutting, chopping.	\$200.00
	MKS-105 Mighty Slicer 10 1/4" Slicing and filleting	\$185.00
	MSL-105 Mighty Slicer 10 1/4" with Dimples. Thinly slice meat, fish, roasts, and ham.	\$150.00

**ULTIMATE SERIES.** Superior Tungsten alloy for the longest lasting edge and heavier bolsters for those who demand the absolute best.





	SBK-95 Ultimate Chef 9" Standard, classic French Chef's. All-purpose use	\$275.00
	SBK-105 Ultimate Chef 10 1/4" 10 1/2" version of the above	\$300.00
	SBK-120 Ultimate Chef 12 1/2" 12" version of the above	\$325.00
	SKS-105 Ultimate Slicer 10 1/4" Slicing and filleting	\$275.00
	SDK-85 Ultimate Cleaver 8 1/2" Chopping through bones & other heavy duty work	\$300.00

**JAPANESE SERIES.** Our Japanese Series feature the traditional single-bevel grind for right-handed use (except for the JU-65 which is V-beveled).

	JU-65 Japanese Veg. 6 1/2" Slicing, dicing fruits & veg.	\$85.00
	BON-60 Japanese Boning 6" Cutting, deboning chicken	\$110.00
	CL-40 Deba Cleaver 4" Filleting fish and cutting through bones	\$65.00
	CL-55 Deba Cleaver 5 1/2" Filleting fish and cutting through bones	\$120.00
	CL-65 Deba Cleaver 6 1/2" Filleting fish and cutting through bones	\$140.00
	CL-75 Deba Cleaver 7 1/2" Cutting fish and bones	\$175.00

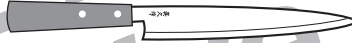
**Yanagiba (Willow Leaf).** Traditional slicer used by Sushi Chefs to fillet and slice fish. Single bevel for right handed users (FKW-9L is available for left handed users)

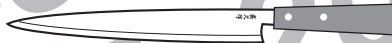
**FKW Series.** One piece Tungsten alloy that resists rust and corrosion. Stronger & more durable than Carbon steel.

	FKW-7 Yanagiba 8"	\$110.00
	FKW-9 Yanagiba 10 1/4" Filleting and slicing fish. SS Tungsten alloy	\$150.00
	FKW-9L Yanagiba 10 1/4" Left Handed Filleting and slicing fish. SS Tungsten alloy	\$170.00
	FKW-10 Yanagiba 11"	\$175.00

**FK Series.** Laminated Carbon steel blade with a harder core for edge retention and softer outer layers for strength. Water Buffalo ring cap. Special attention is required to prevent rust, stains, and minute chips

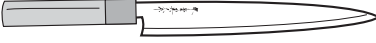
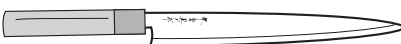
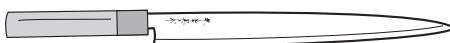
	FK-240 Yanagiba 9 1/2"	\$225.00
	FK-270 Yanagiba 10 1/2" Laminated blade. Used by Sushi Chefs for slicing fish.	\$250.00
	FK-300 Yanagiba 12"	\$275.00

Wooden Scabbards available for all right-handed Yanagiba

